

## Lateral-torsional buckling of a beam

*G.M. Kravchenko, D.S. Kostenko, A.V. Sazonova, K.I. Dolgopolova*

*Don State Technical University, Rostov-on-Don*

**Annotation:** Beams are structural elements subjected to bending loads transverse to their longitudinal axis. For steel beams, which compressed flange is not laterally restrained, checking loss of overall stability is often authoritative in determining their section. In engineering practice are known various approaches to verify the assurance of the steel beam against lateral-torsional buckling. In this article the attention is focused to the methods and their characteristics, described in actual version of the European standard EN1993-1-1.

**Keywords:** lateral-torsional buckling, load-bearing capacity, steel beams, critical bending moment, FEA.

The aim of the work is to determine critical moment for lateral-torsional buckling of a beam. The object of the calculation is hinged – clamped beam which is loaded by concentrated force and moment (Fig. 1). In the first part of the article, Eurocode methodology was used to define the critical moment. The second part describes the analysis of the beam with finite element method approach.

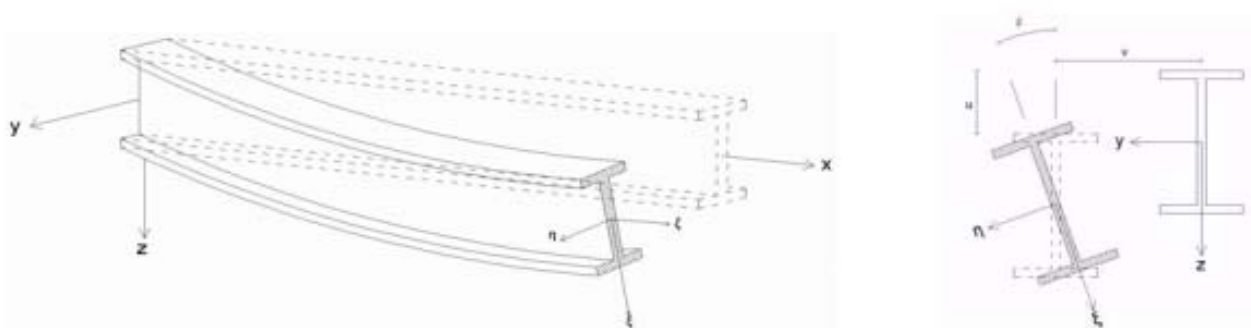

Fig. 1. – Beam deformed configuration associated with the occurrence of LTB

The general parameters of the model are shown in the following figures. Cross-sectional dimensions are illustrated in figure 2. The principal scheme of the beam shows in the figure 3. It is important to highlight that the hinged support represents support where translations are restrained, the twisting rotation is restrained, but the rotation around  $y$  and  $z$  is allowed and warping is allowed. Clamped type of another support means that the translations are restrained, the

twisting rotation is restrained, the rotation around z is restrained, warping is restrained, but the rotation around y is allowed.

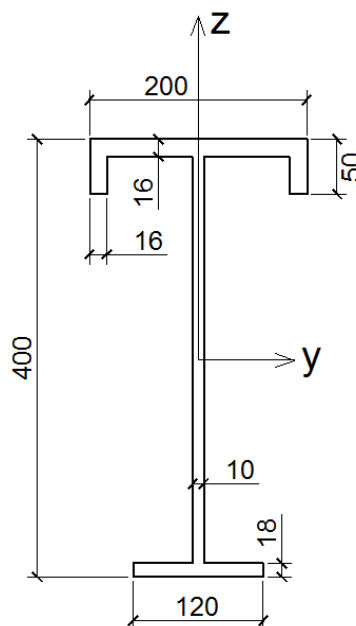

Fig. 2. – Cross-section sizes of the beam

The critical moment of the beam can be obtained according the following formula.

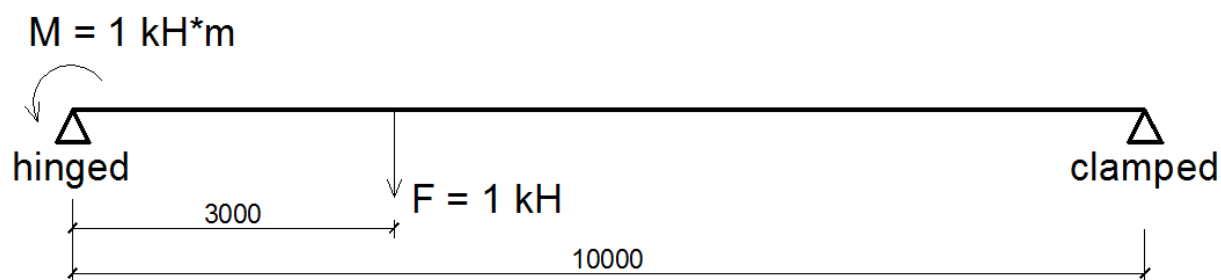

Fig. 3. – Principal scheme of the beam

$$M_{cr} = C_1 \frac{\pi^2 EI_z}{(k_z L)^2} \left\{ \sqrt{\left( \frac{k_z}{k_w} \right)^2 \frac{I_w}{I_z} + \frac{(k_z L)^2 GI_t}{\pi^2 EI_z}} + (C_2 z_g - C_3 z_j)^2 - (C_2 z_g - C_3 z_j) \right\}$$

$C_1$  – factor depending on the moment diagram and the end restraints;

$C_2$  – factor depending on the moment diagram and the end restraints, related to the vertical position of loading;

$C_3$  – factor depending on the moment diagram and the end restraints, related to the monosymmetry of the beam;

$E$  – Young’s modulus of elasticity;

$G$  – shear modulus;

$I_t$  – torsional constant;

$I_w$  – warping constant;

$I_z$  – second moment of area about the minor axis;

$L$  – length of the beam between points which have lateral restraints;

$k_w$  – effective length factor which refers to end warping;

$k_z$  – effective length factor which refers to end rotation in plan;

$z_g$  – coordinate of the point of load application w.r.t. the shear center in the z-direction;

$z_j$  – monosymmetry parameter.

To define three C parameters the Eurocode table was used. The appropriated bending moment diagrams with C-parameters are presented in figure 4.



Bending moment distribution between lateral supports	$\psi$	$k$	$C_1$	$C_2$	$C_3$
	–	1.0 0.5	1.365 1.070	0.553 0.432	1.730 3.050
	–	1.0 0.5	1.565 0.938	1.267 0.715	2.640 4.800

Fig. 4. – Defining of C-parameters

In the previous shown beam the bending moment diagram is not found in the defined cases in EC3, which means that the constant values must be interpolated from similar bending moment cases.

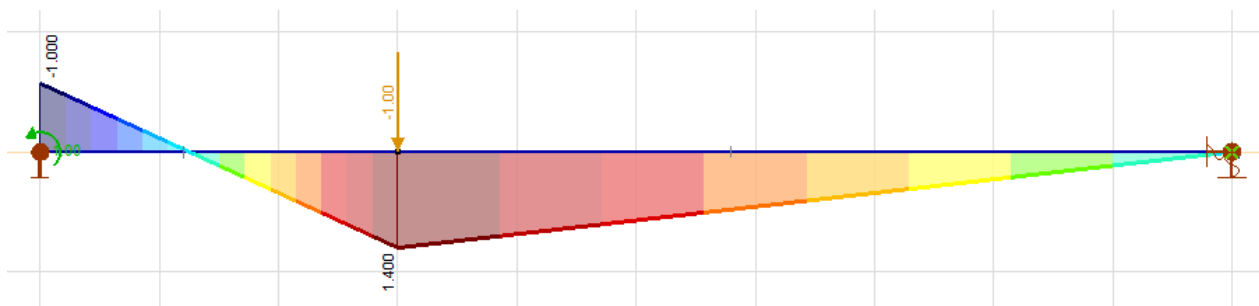

Fig. 5. – Bending moment diagram of the beam

Bending moment diagrams were interpolated with the appropriated values between 2 cases: simple supported beam and continuous beam with  $k = 0,7$  which is taken into account hinged – clamped beam.

k	$C_1$	$C_2$	$C_3$
SS			
1	1,365	0,553	1,730
0,7	1,188	0,480	2,522
0,5	1,070	0,432	3,050
Continuous beam			
1	1,565	1,267	2,640
0,7	1,189	0,936	3,936
0,5	0,938	0,715	4,800
Our case			
0,7	1,886	0,709	3,229

It was assumed that  $C_1 = 1,886$ ,  $C_2 = 0,709$ ,  $C_3 = 3,229$ , then after substitution  $M_{cr} = 752,223 \text{ kN}\cdot\text{m}$ .

To verify analytical solution ANSYS Finite Element Analysis (FEA) software was used. The geometry was created in SolidWorks and exported to ANSYS. The boundary conditionals and load are applied according the Figure 6.

a)

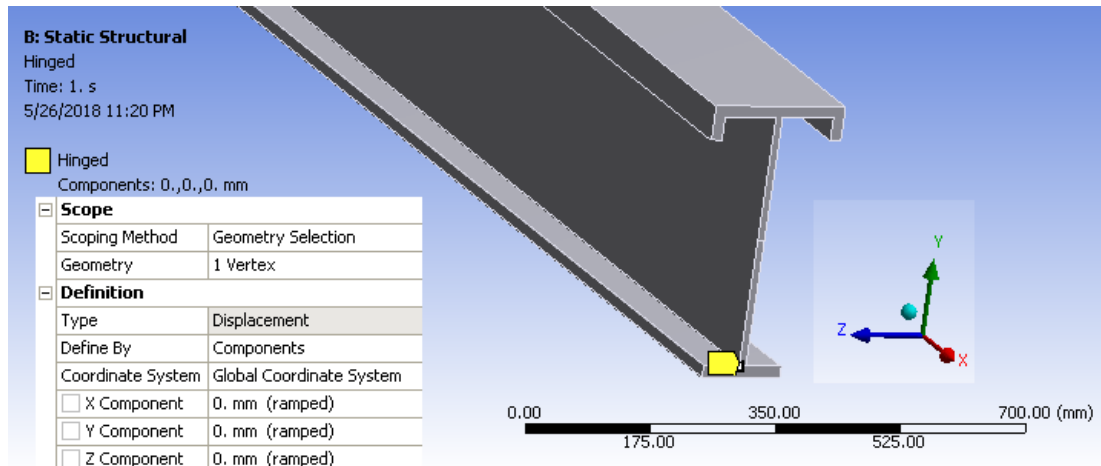

b)

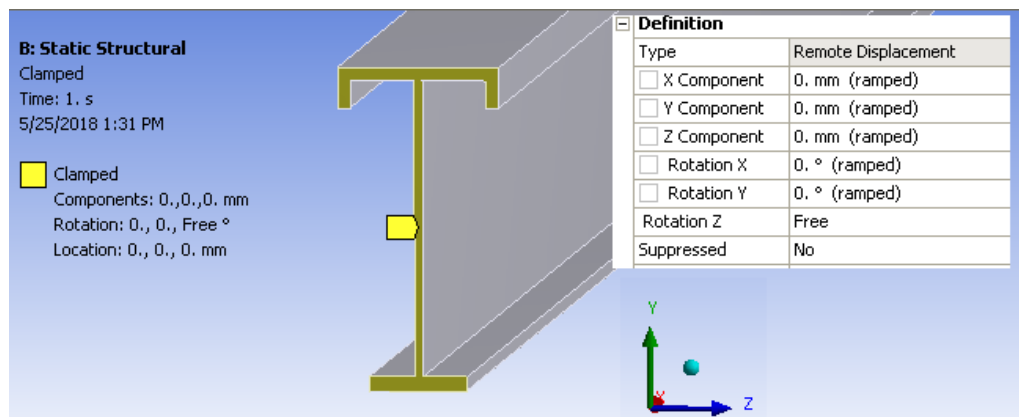

Fig. 6. – Boundary conditions of the beam

The next step is mesh generating of the model. The optimal size of elements can be obtained via iteration process. To solve this problem the size of elements of the model were changing in range from 5 to 0.5 mm. Having this range, for each step values of deflections were compared to the previous one. It is also necessarily to check influence of the element size for the analysed parameter – load multiplier. This relation is shown in the table.

Element size, mm	Load multiplier	Difference, %
5	55,21	

---

3	62,45	13,11
0,5	63,38	1,48

As can be seen from the above table, the difference of the critical moment with 3 mm and 0.5 mm elements size less than 5%, which is acceptable. For the current finite element model we assume elements with 0.5 mm side size. The value of load multiplier according ANSYS is 63,376.

The table shows comparison between analytical solution according EC and FE solution in ANSYS.

	Analytical solution	ANSYS	Difference, %
$M_{cr}, kN \cdot m$	752,22	627,45	19,88

According to the calculations of the critical moment using two methods, a significant difference was found were the error reached 19.88% between the calculated value and the computed one.

### References

1. Bartolomey M.L., Trufanov N.A. Vestnik Permskogo gosudarstvennogo tekhnicheskogo universiteta. Mekhanika. 2009. №1. pp. 15-20.
2. Willam, K.J. and E.D. Warnke, 2013. Constitutive Model for the Triaxial Behavior of Materials. Proceedings, International Association for Bridge and Structural Engineering, 19: p.174.
3. Mailyan D.R., Kurgin K.V. Inzhenernyj vestnik Dona (Rus). 2011. №4. URL: [ivdon.ru/ru/magazine/archive/n4y2011/712](http://ivdon.ru/ru/magazine/archive/n4y2011/712).
4. Mkrtchyan A.M., Mailyan D.R. Inzhenernyj vestnik Dona (Rus), 2013, №4. URL: [ivdon.ru/ru/magazine/archive/n4y2013/2186](http://ivdon.ru/ru/magazine/archive/n4y2013/2186).
5. Fletcher K. Chislennye metody na osnove metoda Galerkina [Numerical methods based on the Galerkin method]. M.: Mir, 2008. 352 p.



6. Sargsjan, A. E. Structural Mechanics and Analysis of Constructions. 1986, № 4. pp. 55-59.
7. Bartolomey M.L., Trufanov N.A. Vestnik Permskogo gosudarstvennogo tekhnicheskogo universiteta. Mekhanika. 2009. №1. pp. 15-20.
8. Nauss D.J. and Lott J.L. Journal of the American Iron and Steel Institute. Vol. 66, No. 6, June, 1975, pp. 481- 489.
9. Willam, K.J. and E.D. Warnke, 2013. Constitutive Model for the Triaxial Behavior of Materials. Proceedings, International Association for Bridge and Structural Engineering, 19: p.174.
10. Guo-Xin Fan, Qing Huo Liu. Fast Fourier transform for discontinuous functions. Antennas and Propagation. IEEE Transactions on. V. 52, Issue: Feb. 2014. pp. 461-465.